

NC DAQ Source Test Observers Checklist - Particulate Testing
EPA Methods 1 - 5 (40 CFR 60 Appendix A)
Line by line explanation and references.

This checklist is not intended to replace familiarity with the reference test methods. It is intended to point out procedures that can be easily checked and will help ensure an accurate, and valid test.

Some items can be filled out prior to the test observation, such as the permit #, source tested, applicable regulation, process data and production rates. This information can be essential in answering questions on-site and determining if enough applicable data is being recorded.

Facility Name / Location: - *Self explanatory*

Facility Contact / Phone #: - *Aids SSCB when contacting facility*

Testing Firm / Contact: - *Aids Regional Office and SSCB when contacting testing firm*

Permit # / Source Tested: - *A quick reference for the regions and SSCB*

Applicable Regulation / Limit:

***Regulation:** SIP Sources require 1hr particulate test runs and a minimum sample of 30 dscf. NSPS regulations may require different sample rates, times, and temperatures. Investigate prior to test.*

Reviewing the applicable regulation (state or NSPS) will aid in the determination of the correct sampling train conditions, the correct process conditions, and the correct operational data.

Process Data / Production Rate:

Process Data: It is absolutely imperative for the facility to record the pertinent data during the test so that the measured emissions can be correlated to a production rate and compared to the permit limit. The test will be unacceptable without production data. A review of the applicable regulation and the permit conditions will aid in determining the correct process rate and the pertinent parameters (throughput, heat input, firing rates, etc.)

Sample Date / Time:

Record the time and the run number(s) when you were present. This data will aid in determining if a DAQ representative was present at specific times / runs. For instance, if a test company states in a report that they had to void run number 2 due to a bad leak check, the regional office or SSCB can review the checklist to confirm the events.

Ask for an explanation to any question answered "No" and attach comments to this form.

The checklist has been created in a "yes or no" format. For most of the questions, 'yes' is the correct answer. Therefore, if the test company responds 'no,' you should request a clarification. It may be a simple mis-understanding on either side or it may be a major error. There are some questions that do not require a 'yes or no' answer. There are other questions that are correctly answered with a 'no' and do not require further explanation.

This page was intentionally left blank.

Method 1 - Sample and Velocity Traverses for Stationary Sources

Method 1 is used to determine if a source's stack meets the correct criteria for testing. The points to be tested within the stack are also determined using Method 1.

1.1) Method 1 calculated correctly (see reverse side)?

Method 1: If stack is between 4" - 12" then Method 1a must be employed. If duct is <4" then alternative methods must be used. (Contact SSCB with any test questions)

Stack Diameter? _____ Measured on site?

Port distance from upstream disturbance (A) _____ Upstream Diameters (A) _____

Port distance from downstream disturbance (B) _____ Downstream Diameters (B) _____

of Sampling Points? _____ (Draw a line vertically from the "Distance A" axis down to the step chart, and from the "Distance B" axis up to the step chart. The maximum # of points marked on the chart yields the minimum # of points to be sampled.)

Method 1 can be found in 40 CFR 60 Appendix A. When the data from the preceding questions is combined with the following charts, the number of sampling points necessary can be determined. The 'Upstream Diameters (A)' value is calculated by dividing the distance from a flow disturbance to the upstream sampling location by the diameter of the stack. The 'Downstream Diameters (B)' value is determined in a similar fashion. If you get confused about the "upstream" and "downstream" definitions, just follow the labeling on the charts. Once you have determined the upstream / downstream diameters, you can transfer those values to the horizontal axis on the charts below. Draw a line vertically from the "Distance A" axis down to the step chart, and from the "Distance B" axis up to the step chart. The maximum # of points marked on the chart yields the minimum # of points that shall be sampled.

Method 1 - stacks with diameters > 12 inches

Particulate traverses - Method 1, section 2.2.1

Velocity traverses - Method 1, section 2.2.2

Method 1A - stacks with diameters between 4-12 inches.

Stacks smaller than 4 inches will require alternative methodology.

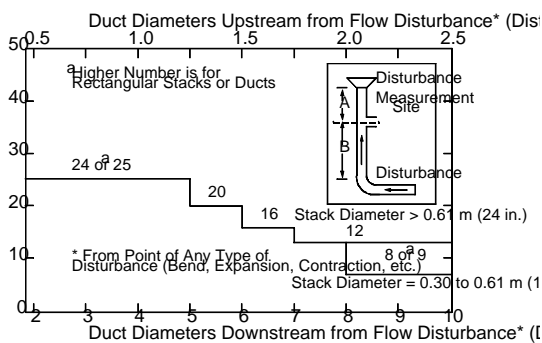

Figure 1-1. Minimum number of traverse points for particulate traverses.

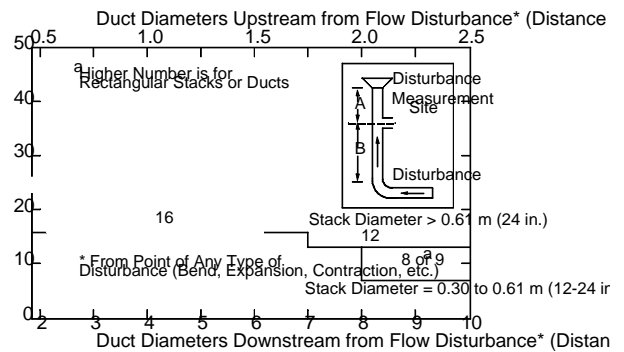

Figure 1-2. Minimum number of traverse points for velocity (nonparticulate) traverses.

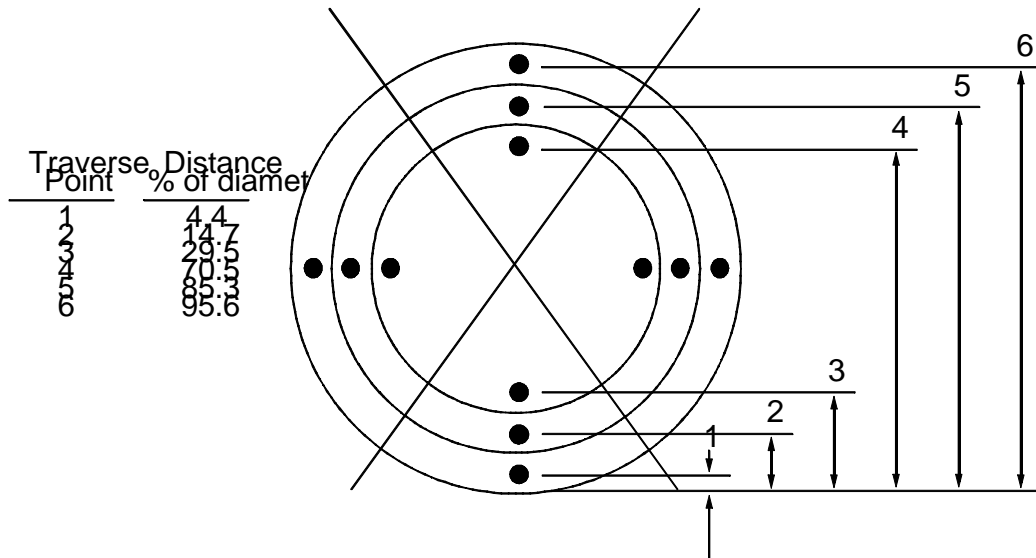

Figure 1-3. Example showing circular stack cross section divided into 12 equal areas, with location of traverse points indicated.

TABLE 1-2 LOCATION OF TRAVERSE POINTS IN CIRCULAR STACKS
(Percent of stack diameter from insidewall to traverse point)

Traverse Point Number on a Diameter	Number of traverse points on a diameter											
	2	4	6	8	10	12	14	16	18	20	22	24
1	14.6	6.7	4.4	3.2	2.6	2.1	1.8	1.6	1.4	1.3	1.1	1.1
2	85.4	25.0	14.6	10.5	8.2	6.7	5.7	4.9	4.4	3.9	3.5	3.2
3		75.0	29.6	19.4	14.6	11.8	9.9	8.5	7.5	6.7	6.0	5.5
4		93.3	70.4	32.3	22.6	17.7	14.6	12.5	10.9	9.7	8.7	7.9
5			85.4	67.7	34.2	25.0	20.1	16.9	14.6	12.9	11.6	10.5
6			95.6	80.6	65.8	35.6	26.9	22.0	18.8	16.5	14.6	13.2
7				89.5	77.4	64.4	36.6	28.3	23.6	20.4	18.0	16.1
8				96.8	85.4	75.0	63.4	37.5	29.6	25.0	21.8	19.4
9					91.8	82.3	73.1	62.5	38.2	30.6	26.2	23.0
10					97.4	88.2	79.9	71.7	61.8	38.8	31.5	27.2
11						93.3	85.4	78.0	70.4	61.2	39.3	32.3
12						97.9	90.1	83.1	76.4	69.4	60.7	39.8
13							94.3	87.5	81.2	75.0	68.5	60.2
14							98.2	91.5	85.4	79.6	73.8	67.7
15								95.1	89.1	83.5	78.2	72.8
16								98.4	92.5	87.1	82.0	77.0
17									95.6	90.3	85.4	80.6
18									98.6	93.3	88.4	83.9
19										96.1	91.3	86.8
20										98.7	94.0	89.5
21											96.5	92.1
22											98.9	94.5
23												96.8
24												98.9

For rectangular ducts, the same process is used to determine how many points need to be sampled. However, the method requires a calculation of an equivalent diameter based on the dimensions of the duct. That equivalent diameter is then divided into the upstream / downstream distances. The number of points is chosen in the same manner as above.

$$D_e = \frac{2LW}{L + W}$$

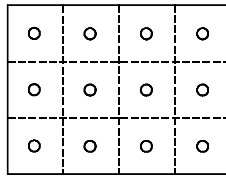

Figure 1-4. Example showing rectangular stack cross section divided into 12 equal areas, with a traverse point at centroid of each area.

Table 1-1. CROSS-SECTION LAYOUT FOR RECTANGULAR STACKS

Number of traverse points	Matrix layout
9	3x3
12	4x3
16	4x4
20	5x4
25	5x5
30	6x5
36	6x6
42	7x6
49	7x7

Review Method 1 to determine the placement of the points once the number of points have been determined.

1.2) Cyclonic flow check completed? (Average of absolute value of all angles <20 degrees?)

Method 1, section 2.4.

The effluent within a stack does not always travel linearly. The introduction of the gas stream into a stack at a tangential angle can create an effluent cyclone within the stack. The presence of cyclonic flow is not desirable for testing emissions from the stack. Essentially, most of the sampling equipment was not designed to take measurements in non-linear flow. Combined with the characteristics of particle motion, flow and pollutant stratification, cyclonic flow is undesirable for a sampling location. How linear must the flow be? Method 1 has states that the flow must be less than 20 degrees, on average, from the axis of the flue. In other words, the angle of non-axial flow (axial would be perfectly vertical flow in a vertical stack and perfectly horizontal in a horizontal duct) must be measured at each point, prior to beginning the test. The average of each individual angle shall be less than 20 degrees. A pitot tube, which is used in Method 2 to measure the flow rate, and an angle finder are used to determine the angle of the effluent, relative to the flue walls, at each sampling point.

This page was intentionally left blank.

Method 2 - Determination of Stack Gas Velocity and Volumetric Flow Rate

2.1) Pitot tube leak check completed after each run?

The pitot tube is inserted in the stack and the flow stream impacts on one side of the pitot head. The two sides of the pitot tube are connected by two lines (typically called a pitot umbilical) to the two sides of a sealed manometer. The effluent gas stream does not pass from one side of the pitot, through the manometer and out the other side of the pitot. The effluent creates a pressure differential (Δp) between the two pitot heads. The magnitude of the differential pressure is measured on the manometer. Therefore, it is imperative to ensure a leak free system. A pitot tube leak check should be performed after each run. If the leak check fails, the runs between the failed leak check and the previous passed leak check should be invalidated.

40CFR60 M2, section 3.1: "It is recommended, but not required, that a pretest leak-check be conducted, as follows: (1) blow through the pitot impact opening until at least 7.6 cm (3 in.) H₂O velocity pressure registers on the manometer; then, close off the impact opening. The pressure shall remain stable for at least 15 seconds; (2) do the same for the static pressure side, except using suction to obtain the minimum of 7.6 cm (3 in.) H₂O. Other leak-check procedures, subject to the approval of the Administrator, may be used." ... "Conduct a post-test leak-check (mandatory), as described in Section 3.1 above, to validate the traverse run."

Other procedures may include closing off both sides of the pitot tube at once through a single piece of tubing. This procedure will create a loop out of the entire system. Keep in mind that the entire pitot tube system, assembled for testing, must be leak checked. The fluid within the manometer is a viscous oil and will therefore run down the walls of the manometer tube. This may appear to be a leak since the level of the oil will be increasing, but eventually the oil level will become steady. There have been questions about what "stable" means - how much deviation is allowed? Ideally, no leaks, and therefore no change in manometer fluid level should occur.

2.2) Visual check of pitot tube heads - good condition?

40CFR60 M2, section 2.1 & figures 2-1, 2-2, and 2-3.

The type S pitot head is assigned a coefficient of 0.84, which will be used in velocity calculations, if the pitot tube meets certain dimensional limits. Since the pitot tube is not required to be calibrated,

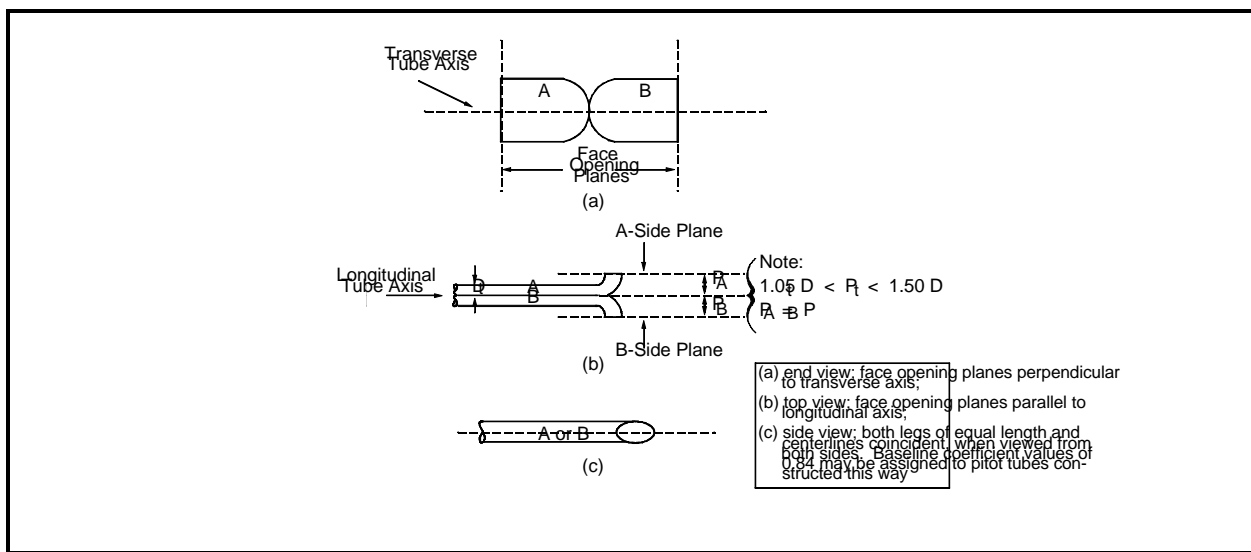
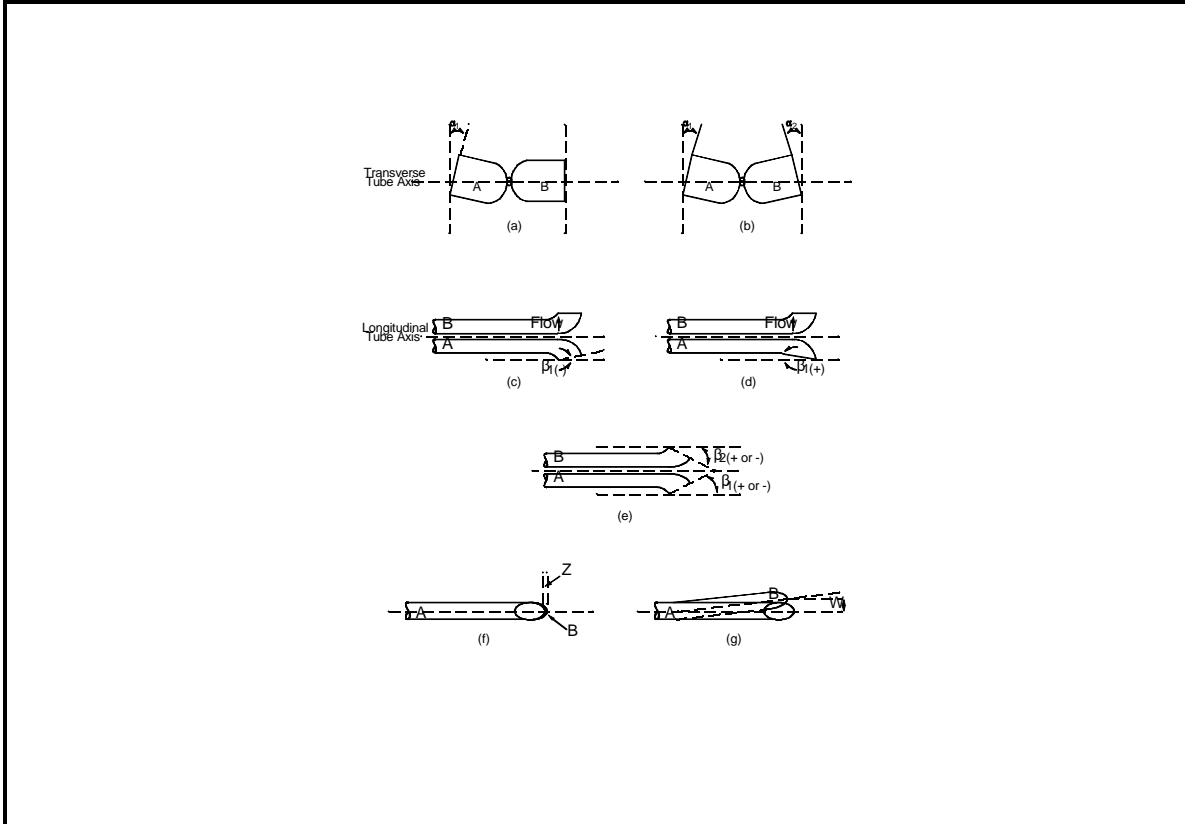

Figure 2-2. Properly constructed Type S pitot tube.



it is important for the pitot tube to remain in good condition. Comparing the pitot heads to the figures in the CFR will determine if the pitot tube is acceptable. Look for damaged, crushed, or flattened heads as well as any other mis configuration. This procedure can be performed prior to the beginning of the test run or after the run is complete.

2.3) Manometer level and zeroed correctly?

40CFR60 M2, section 3.2

Since the manometer measures the differential pressure of the pitot tube heads, it is imperative that the manometer is level and the fluid has been adjusted to read zero before the test run. In order to get a "differential pressure" we must know the "original" pressure and then subtract it from the "measured" pressure. If we set the "original" pressure to zero, the "measured" pressure will be the value indicated by the fluid level on the manometer scale. Similarly, since the manometer scale was defined with a level reference, if the scale is slanted, the fluid's position on the scale will not indicate an accurate delta P. Prior to each run, the level and the zero should be checked. The test team may also want to check the level and zero between port changes especially when the manometer must be moved. The leveling should occur first so that the zero reading is not biased. There should be a leveling bubble built into the body of the manometer. The manometer can be adjusted on one corner until the bubble indicates a level position. The manometer reading is made by aligning the bottom of the fluid meniscus with the reflection of the meniscus on the mirrored background. The zero reading is taken while the pitot heads are covered so that there is no impaction from the wind. The adjustment for the zero level is made by adjusting the fluid level in a reservoir built into the manometer. The procedure may need to be performed multiple times on days with great temperature fluctuations, due to the expansion / contraction of the manometer fluid.

2.4) Static pressure measured during the test day?

40CFR60 M2, section 3.4

The static pressure basically measures the difference in absolute pressure from the ambient atmosphere to the gases within the stack. The static pressure value is used in the calculation of gas velocity and volumetric flow rate. The measurement is made with the same pitot tube used for velocity measurements. During velocity measurements, the pitot tube is oriented such that the plane of the pitot head opening is perpendicular to the flue's longitudinal axis so that the gas stream will impact on the opening. When the static pressure is measured, the pitot tube heads are rotated until there is a null (zero) reading on the manometer. A null reading indicates that the plane of the pitot head openings is parallel to the direction of the flow and therefore, effluent is not impacting on the pitot head creating a differential pressure reading on the manometer. Once the manometer yields a null reading, one side of the manometer is disconnected from the pitot tube. The pressure of the ambient atmosphere will be applied to one side of the manometer and the pressure of the effluent gases will be applied to the other side. The difference in the two pressures is termed the static pressure. A positive static pressure occurs when the effluent gas pressure is greater than the atmospheric pressure. A negative pressure occurs when the ambient pressure is greater than the stack gas pressure. A physical inspection of the sampling port can aid in determining whether the static pressure is positive or negative. If effluent is blowing out at the sampling port, the static pressure is probably positive. If ambient air is being drawn into the port opening, then the static pressure is probably negative. If the gases at the port 'puff' in and out, then the static pressure may be negligible. In all cases, the static pressure shall be measured.

2.5) Barometric pressure recorded and adjusted for elevation? (see reverse side)

40CFR60 M2, section 2.5

“Barometric pressure must be adjusted minus 0.1" per 100ft elevation increase or vice versa for elevation decrease. (Elevation at which barometric pressure is measured compared to the elevation at the test platform.)”

An accurate value for barometric pressure is important for the velocity and volumetric flow rate calculation. Barometric pressure will change due to altitude by the relationship given above. Testing firms may have equipment to measure barometric pressure at the sampling location. Others may rely on the data generated at a control room, air port, or National Weather Service station. If sampling is occurring at a 300 foot location and the barometric pressure was measured at an airport 100 feet lower than the source's elevation, a correction of $(0.1 \times 3 + 0.1 \times 1 = 0.4)$ minus 0.4 inches must be applied to the measured barometric pressure.

2.6) Pitot tube heads oriented to axis of flue? / Pitot tube perpendicular to axis of stack?

The pitot tube performs its designed function when the effluent impacts the pitot head opening in a perpendicular direction. Therefore, the pitot heads must be aligned to the axis of the flue so that the pitot head opening plane is perpendicular to the direction of flow and perpendicular to the stack walls. This assumes that the direction of the effluent and the axis of the flue are parallel. EPA has set forth an acceptable deviation for the direction of flow (20 degrees) as was addressed in the discussion of cyclonic flow. In order to ensure standardized, reproducible result, the pitot heads shall be oriented to the axis of the flue. The pitot tube should be inserted in the flue and remain at a perpendicular angle to the flue. For example, if the testing is occurring at a vertical stack, the pitot tube should be parallel to the ground, and the pitot must be perpendicular to the stack. The pitot tube must be perpendicular to the stack so that the path of travel for the pitot is across a diameter of the cross section.

2.7) Temperature recorded at each sampling point?

40CFR60 M2, section 3.3

As the pitot tube traverses the cross section of the stack, the differential pressure (Δp) and the temperature shall be measured at each sampling point determined in Method 1. A thermocouple should be attached to the pitot tube and an average temperature for the effluent can be determined. The temperature read out at each point should be allowed to stabilize prior to recording the data.

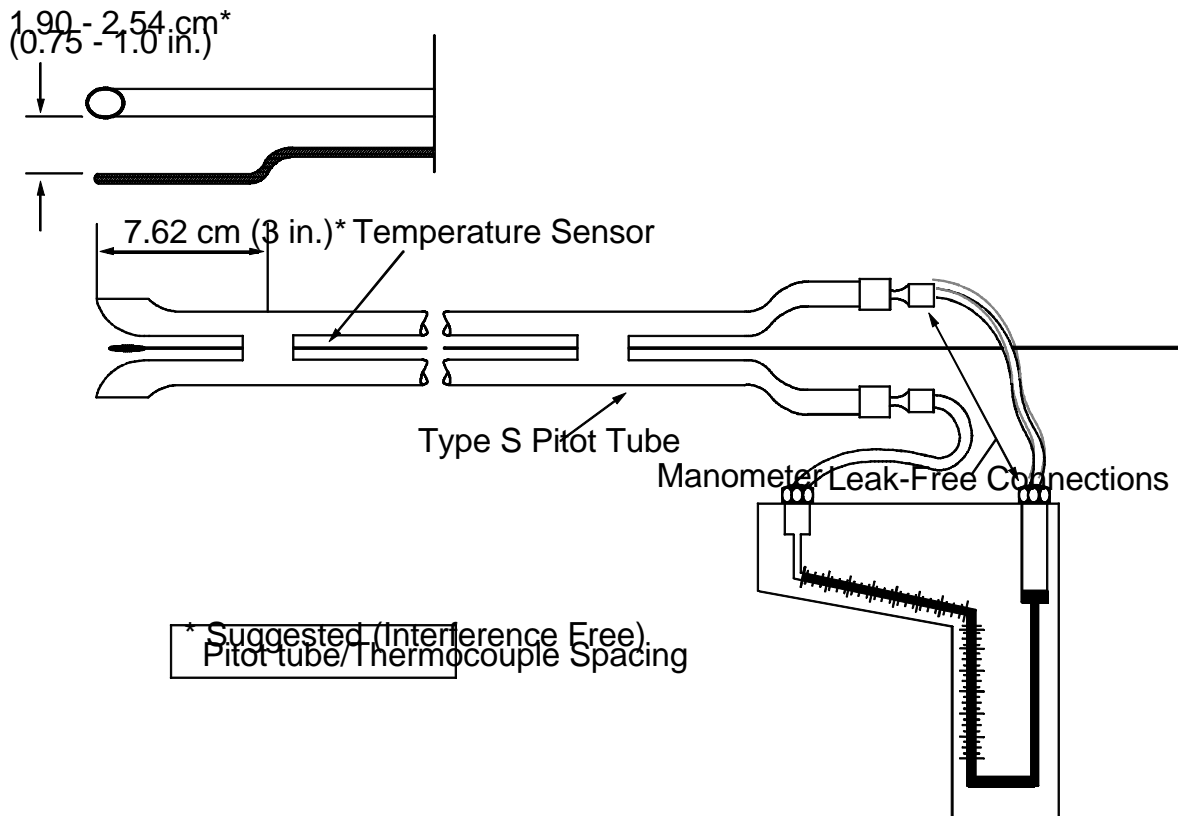

Figure 2-1. Type S pitot tube manometer assembly.

Method 3 - Gas Analysis for O₂, CO₂, and Dry Molecular Weight

During a particulate test, the molecular weight of the gas stream shall be measured in order to calculate the flow rate. MW is determined by the ratios of O₂, CO₂, and CO in the following equation:

$$M_d = \text{Dry Molecular weight of the gas stream}$$
$$M_d = 0.440(\%CO_2) + 0.320(\%O_2) + 0.280(\%N_2 + \%CO)$$
$$\%N_2 = 100 - (\%CO_2 + \%O_2)$$

Typically, carbon monoxide is not measured for MW determinations since it is multiplied by the same factor as N₂. Therefore, once the O₂ and CO₂ concentrations are measured, the remainder of the gases with percentage concentrations are assumed to be N₂.

3.1) Multi point integrated sample / Bag evacuated and leak free?

40CFR60 M3, section 5.1, 2.2.6, & M5, section 4.1.2

When performing a particulate matter test, all supporting effluent data should be recorded at the same time and position (as best possible) as the capture of the particulate pollutant. Therefore, the O₂ & CO₂ measurements should occur at the same sampling points as the particulate measurements. This will satisfy the multi point analysis requirement. Since a sample of the effluent gas is being collected during the entire run, the condition of an integrated sample is satisfied. Typically, there will be a small probe attached to the side of the M5 sampling probe. This secondary probe, with the aid of a small pump, will continuously extract a sample of the effluent as the stack is traversed. Therefore, the sample will be multi-point and integrated.

With respect to the evacuated and leak free bag; it probably will not be necessary to request a demonstration of a leak free bag. It is proper to request confirmation that the bag is leak free. There are two primary ways to collect the O₂ / CO₂ sample: 1. Directly inject the gas into the sample bag. This will create a positive pressure situation which should not allow the introduction of diluents to the sample. 2. The sample is collected by a lung sampler. A sample bag is placed in a rigid, sealed container and the container is evacuated. Thus, the bag fills with effluent. This is a negative pressure situation. However, if there is a leak in the sample bag, the negative pressure will remove effluent rather than introduce diluent air. Regardless, under any situation, the sample bag shall be a leak free bag.

The sample bag shall be evacuated of any other gases. This will ensure that old sample gas or diluent air will not bias the analysis results.

The main opportunity for error in the M3 sampling occurs when the equipment is moved. During sampling port changes, the M3 sample pump shall be turned off or the gas being pumped shall be expelled to the atmosphere and not introduced into the bag. If ambient air is introduced into the bag during port changes, the O₂ / CO₂ concentrations may be significantly biased. If this occurs, the bag shall be re-evacuated and then filled with gas from the remainder of the particulate test run.

If the test company uses an electronic analyzer for the analysis, a multi point integrated sample will still need to be taken. The analysis may occur by extracting the sample gas from a bag, or the analyzer may measure the diluent gases real time, directly from the sample line.

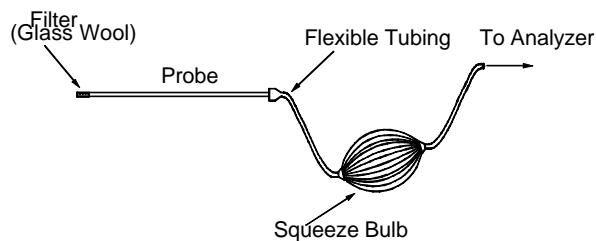

Figure 3-1. Grab-Sampling Train.

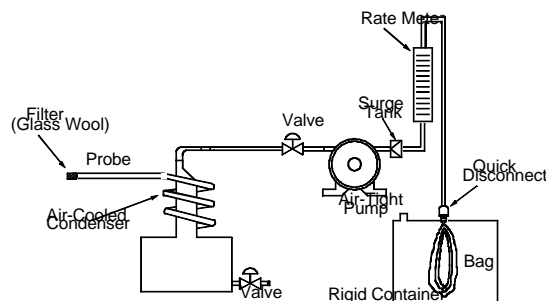

Figure 3-2. Integrated gas-sampling train.

3.2) Orsat, electronic analyzer, or Fyrites used? (circle)

The O₂ & CO₂ determinations are performed using an Orsat (O₂ & CO₂) or a Fyrite (for CO₂ only). The analysis is performed by introducing a sample of the effluent (typically collected in a bag) to the Orsat or Fyrite equipment. There is one reagent used to absorb O₂ and a different reagent used to absorb CO₂. Due to the gas absorption, there will be a difference in gas volume within the analyzer that can be measured on a scale. The Orsat is the preferred wet chemistry method for O₂ and CO₂ determinations. The Fyrite may be used for CO₂ but is not allowed for O₂ by the NCAC .0501 regulation.

The measured O₂ concentration is an important variable in the lb/mmBtu calculation; a small error in the O₂ measurement can create a large error in the emission calculation that may effect the compliance status of a source.

An electronic analyzer is acceptable, provided the calibration specifications in Method 3A are followed. (See the CEM checklist reference document under Method 3)

“Orsat, Analyzer or Fyrites: *The measurement of O₂ & CO₂ is usually performed with an Orsat. However, it is acceptable to use an analyzer if it has been calibrated per Method 3A.*

Fyrites are acceptable for CO₂ measurement. An O₂ Fyrite can be grudgingly accepted when the results are used to calculate molecular weight only. In no case shall an O₂ Fyrite be accepted if the emission standard is in terms of lb/mmBtu or corrected to a percentage of oxygen.”

3.3) Orsat performed in triplicate? Analysis consistent?

40CFR60 M3, section 3.4

The analysis shall be performed on one sample per test run. When the Orsat analysis is performed, the test company should make three separate measurements on each run’s sample. The three analysis, on the same sample, should not differ greatly.

“3.4 Repeat the sampling, analysis, and calculation procedures until the dry molecular weights of any three grab samples differ from their mean by no more than 0.3 g/g-mole (0.3 lb/lb-mole). Average these three molecular weights, and report the results to the nearest 0.1 g/g-mole (0.1 lb/lb-mole).”

“**Orsat Triplicate:** For each test run there must be three individual analysis of the O₂ & CO₂ concentrations in the flue gas. The analysis must be repeated until the following analysis criteria is met:

CO₂ - any three analyses differ by
 a) <0.3% when CO₂ > 4.0%
 b) <0.2% when CO₂ < 4.0%

O₂ - any three analysis differ by
 a) <0.3% when O₂ > 15.0%
 b) <0.2% when O₂ < 15.0%”

3.4) Calculate F_o / Within range?

40CFR60 M3B, section 3.4

If the source is combustion based, a quick calculation can aid in determining the validity of the O₂, CO₂ data.

Calculate F_o:

$$F_{O} = \frac{(20.9 - \%O_2)}{\%CO_2}$$

Coal:	Anthracite and lignite	1.016 - 1.130	Gas:	Natural	1.600 - 1.836
	Bituminous	1.083 - 1.230		Propane	1.434 - 1.586
Oil:	Distillate	1.260 - 1.413		Butane	1.405 - 1.553
	Residual	1.210 - 1.370	Wood:		1.000 - 1.120

The Fo referenced in Method 3B is not the Fuel Factor (F-factor) defined in Method 19 that is used for emissions calculations. Performing the calculation and confirming that the value is within acceptable limits is only a QA check. If the Fo value falls outside of the range, then the test company should be questioned about the data. However, only being out of Fo range does not constitute an un-acceptable measurement. It is possible that the Fo value is out of range based on accurate O₂ / CO₂ data.

This page was intentionally left blank.

Method 4 - Determination of Moisture Content in Stack Gases

4.1) Impingers used or some other type of condenser? Multi point sample?

40CFR60 M4, section 2.1.2 & 2.2.1

The most common moisture determination system is the impinger train that is used on the back side of a Method 5 sampling train. The impinger train is the Method 4 part of the Method 1-5 sampling train. The impinger train can be used by itself, when particulate determinations are not necessary, to determine the moisture content.

2.1.2. ...“Alternatively, any system may be used (subject to the approval of the Administrator) that cools the sample gas stream and allows measurement of both the water that has been condensed and the moisture leaving the condenser, each to within 1 ml or 1 g.”

A traverse of the flue should occur in order to ensure representativeness of the moisture determination:

“2.2.1 Unless otherwise specified by the Administrator, a minimum of eight traverse points shall be used for circular stacks having diameters less than 0.61 m (24 in.), a minimum of nine points shall be used for rectangular stacks having equivalent diameters less than 0.61 m (24 in.), and a minimum of twelve traverse points shall be used in all other cases. The traverse points shall be located according to Method 1. The use of fewer points is subject to the approval of the Administrator.”

4.2) H₂O in first 2 impingers, 3rd impinger empty, silica gel in 4th impinger?

40CFR60 M4, section 2.1.2

“2.1.2 Condenser. The condenser consists of four impingers connected in series with ground glass, leak-free fittings or any similarly leak-free non-contaminating fittings..... The first two impingers shall contain known volumes of water, the third shall be empty, and the fourth shall contain a known weight of 6- to 16-mesh indicating type silica gel, or equivalent desiccant.”

4.3) Temperature at the exit of impingers / condenser <68F? (see reverse side)

40CFR60 M4, section 2.2.5

“2.2.5 To begin sampling, position the probe tip at the first traverse point. Immediately start the pump and adjust the flow to the desired rate. Traverse the cross section, sampling at each traverse point for an equal length of time. Add more ice and, if necessary, salt to maintain a temperature of less 20 C (68 F) at the silica gel outlet.”

The outlet temperature of less than 68 degrees ensures that the sample is relatively dry before exiting the train, and it approximates the “standard” temperature used for calculations.

“Exit Temperature: The temperature of the dry gas leaving the impingers/condenser must be below 68F. When the ambient temperature is above 68F it may take approximately 5 minutes for the thermal effects of the ice bath to cool the exit thermometer below 68F.”

4.4) Silica gel in good condition? - Blue-new, Pink-spent (unable to absorb more H₂O)

Most silica gel used for moisture determinations is the "indicating" type. Dark colored (blue, purple) silica gel can absorb water from the gas stream. Light colored silica gel (pink, white) has lost most of its absorptive capacity. As the test run is performed, the silica gel will absorb more and more moisture from the effluent. The gas contacts the silica gel at the bottom of the impinger first, since the gas enters through the impinger stem (like a straw). Silica gel at the bottom of the impinger will change color first. If all of the silica gel has turned a pale color by the end of the run, some moisture may be passing through the train. The sampling team should use new silica gel and may choose to use more silica gel.

Method 5 - Determination of Particulate Emissions from Stationary Sources

5.1) Methods 2 - 5 run concurrently?

40CFR60 M5 including section 2.1.10

When a method 5 test is performed, Methods 1-4 are inherently performed as well. Method 1 determines the points that the M5 train will sample. Method 2 determines the velocity head (and ultimately the flow rate) that will be used for isokinetic calculations, an integral part of performing an M5. Method 3 determines the molecular weight and provides data for emissions calculations. The M3 is required to be performed simultaneously with the M5. Method 4 determines the percentage of moisture in the gas stream for flow rate calculations. It is also an integral part of the M5 since the hot / wet gas stream entering the nozzle and passing through the filter must be cooled and dried prior to being measured on the dry gas meter.

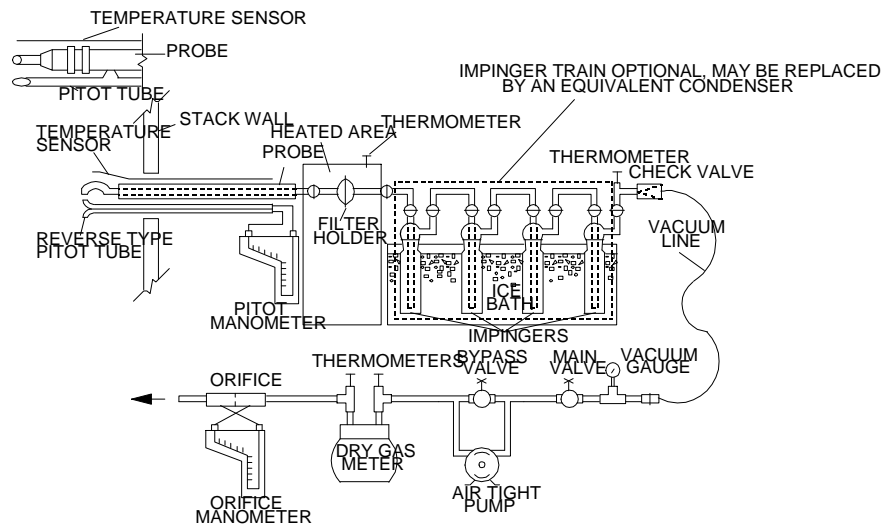

Figure 5-1. Particulate Sampling Train

5.2) Visually inspect sample nozzle for damage / Nozzle opening facing direction of flow?

40CFR60 M5, section 2.1.1 & 5.1

The nozzle used for particulate sampling has been designed to have the least amount of interference on the streamlines of the effluent. Since fine particles follow streamlines, any interruption of the gas stream can interfere with the particles caught. (This includes damage to the sample nozzle and jagged nozzle edges) There are specifications in the CFR for nozzle dimensions. At a minimum, ensure that the nozzle opening is round without interferences. Bent, indented, jagged nozzles should not be used for sampling.

Ensure that the nozzle is pointed in the direction of the flow. A particulate test that is performed with the nozzle facing away from the particulate laden gas stream is meaningless. Also, ensure that the nozzle is oriented parallel with the duct / stack walls. If the nozzle is angled away from the direction of flow, the final data may be biased.

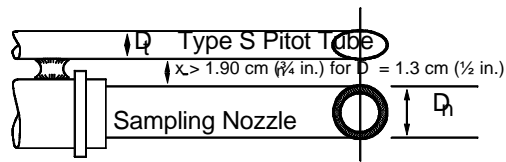

A. Bottom View; showing minimum pitot tube-nozzle separation.

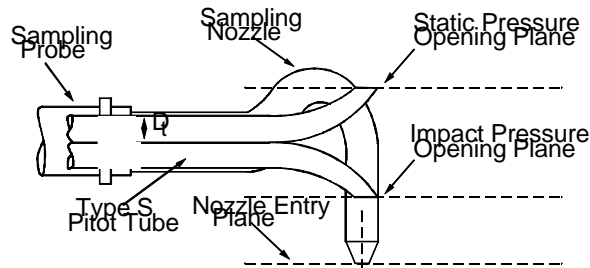

B. Side View; to prevent pitot tube from interfering with gas flow streamlines approaching the nozzle, the impact pressure opening plane of the pitot tube shall be even with or above the nozzle entry plane.

Figure 2-6. Proper pitot tube-sampling nozzle configuration to prevent aerodynamic interference; button-hook type nozzle; centers of nozzle and pitot opening aligned; D_1 between 0.48 and 0.95 cm (3/16 and 3/8 in.).

5.3) Pre test run leak check, optional (watch) Leak Rate <0.02cfm?

40CFR60 M5, section 4.1.4.1

A pre-test leak check is performed to ensure the integrity of the sample train prior to beginning the test. While the pre-test leak check is not mandatory, the test team will be taking a tremendous risk of invalidating an entire run if the check is not performed and the post test leak check fails. See the procedure for the leak check below.

5.4) Post test run leak check, mandatory (watch) Leak Rate <0.02cfm?

40CFR60 M5, section 4.1.4.3

Upon completion of the sampling run, the probe is extracted from the stack and allowed to cool. The leak check procedure consists of sealing off the end of the nozzle (typically with a finger) and creating a vacuum in the system, via the sample pump, that is equal to or greater than the maximum vacuum rate achieved during the test run. There shall be no tightening of connections (impinger, probe, or sample line connections) prior to the successful completion of a leak check. If tightening occurs, a potential leak could have been repaired. The leakage rate is measured on the dry gas meter dial over the period of 1 minute. Discretion can be used however; if the dial does not move for a constant 15-30 seconds, it is usually safe to assume that the leak rate of 0.02 cubic feet per minute will not occur.

“Leak Check: If the results of the leak check indicate a leak (>0.02cfm), record the leakage rate. Suggest repeating the run, but it is the discretion of the test team and facility to accept the leak. However, the sample volume will be adversely adjusted due to the leakage rate.”

5.5) Nozzle Diameters Run 1, 2, 3:

40CFR60 M5, section 4.1.2 & 5.1

This data will provide confirmation of the results submitted in the test report. Request the information from the test team and request for a measurement to be performed on-site. While on-site measurements are not mandatory, if the company has measuring calipers, this will provide added assurance of the data accuracy.

5.6) Isokinetic rates between 90% and 110%?

40CFR60 M5, section 4.1.5 & 6.12

Isokinetics describes the velocity of the sample gas entering the nozzle relative to the velocity of the effluent stream. Since particles are affected by streamlines and the differential velocities will create non-linear stream lines, ensuring isokinetics between 90 and 110% will ensure the minimum interference due to sample train operation. Request this information from the test team between runs. A true isokinetic calculation can be performed after the run, once all of the data (except for particulate catch weight) is collected.

“Isokinetics: If the test team indicates that the isokinetic rate of a run is over 110% or under 90%, the run should be voided and repeated.”

5.7) Filter and probe temperatures at 248 +/- 25F (or applicable subpart)?

40CFR60 M5, section 1.1 & 2.1.6

The M5 test is basically a “benchmark” test. It provides a standard that can be used to measure particulate emissions from various sources. The phenomenon of particulate matter is greatly dependent on temperature. M5 even states: “The particulate mass, which includes any material that condenses at or above the filtration temperature...” Therefore, if the filtration temperature changes, the “type” and quantity of particulate caught will also change. For most NSPS and SIP sources, the filtration temperature shall be 248 +/- 25 degrees F. When you review the applicable regulation (i.e. NSPS), the filter temperature may be increased .

5.8) During a run, was any equipment changed (ie. filter, nozzle, impinger) and why? (Do not explain a "No")

40CFR60 M5, section 4.1.5

Sometimes it is necessary to replace equipment during a run.

Some examples include: 1. The particulate loading is so great creating a blockage of the filter and a vacuum in the sample train that is unmanageable (ie >15-20"). 2. The selected nozzle is inadequate based on the delta p readings currently being taken. 3. The silica gel in an impinger is rapidly becoming spent.

All subsequent calculations shall include any data and material taken prior to the equipment change. If the test team changes any equipment, there shall be a successful leak check performed prior to the equipment adjustment.

5.8a) Was a leak check performed prior to the equipment change? (May not be applicable)

40CFR60 M5, section 4.1.5

If the test team changes any equipment, there shall be a successful leak check performed prior to the equipment adjustment.

5.9) Meterbox calibration values - ΔH@:, Y:, Date Calibrated:

40CFR60 M5, section 7

*The delta H at, and Gamma ($\Delta H@:$, Y) are functions of the meterbox and are integral in calculating the emissions and confirming accurate measurement equipment.
Recording the data in the field will help validate the test report.*

5.10) Filter numbers Run 1, 2, 3:

40CFR60 M5, section 3.1.1 & 4.1.3 & 4.3

The test company relies on numbers to identify the filters used for each run. Typically, the number will be stamped on one side of the filter (which will be positioned as the clean side). Request the filter numbers for individual runs.

Recording the data in the field will help validate the test report.

5.11) Particulate sample clean-up:

40CFR60 M5, section 4.2

The most exact summary of the clean-up procedure is written in the method:

4.2 Sample Recovery. Proper cleanup procedure begins as soon as the probe is removed from the stack at the end of the sampling period. Allow the probe to cool. When the probe can be safely handled, wipe off all external particulate matter near the tip of the probe nozzle and place a cap over it to prevent losing or gaining particulate matter. Do not cap off the probe tip tightly while the sampling train is cooling down as this would create a vacuum in the filter holder, thus drawing water from the impingers into the filter holder. Before moving the sample train to the cleanup site, remove the probe from the sample train, wipe off the silicone grease, and cap the open outlet of the probe. Be careful not to lose any condensate that might be present. Wipe off the silicone grease from the filter inlet where the probe was fastened and cap it. Remove the umbilical cord from the last impinger and cap the impinger. If a flexible line is used between the first impinger or condenser and the filter holder, disconnect the line at the filter holder and let any condensed water or liquid drain into the impingers or condenser. After wiping off the silicone grease, cap off the filter holder outlet and impinger inlet. Either ground-glass stoppers, plastic caps, or serum caps may be used to close these openings. Transfer the probe and filter-impinger assembly to the cleanup area. This area should be clean and protected from the wind so that the chances of contaminating or losing the sample will be minimized.

Save a portion of the acetone used for cleanup as a blank. Take 200 ml of this acetone directly from the wash bottle being used and place it in a glass sample container labeled "acetone blank." Inspect the train prior to and during disassembly and note any abnormal conditions. Treat the samples as follows:

Container No. 1. Carefully remove the filter from the filter holder and place it in its identified petri dish container. Use a pair of tweezers and/or clean disposable surgical gloves to handle the filter. If it is necessary to fold the filter, do so such that the particulate cake is inside the fold. Carefully transfer to the petri dish any particulate matter and/or filter fibers which adhere to the filter holder gasket, by using a dry Nylon bristle brush and/or a sharp-edged blade. Seal the container.

Container No. 2. Taking care to see that dust on the outside of the probe or other exterior surfaces does not get into the sample, quantitatively recover particulate matter or any condensate from the probe nozzle, probe fitting, probe liner, and front half of the filter holder by washing these components with acetone and placing the wash in a glass container. Distilled water may be used instead of acetone when approved by the Administrator and shall be used when specified by the Administrator; in these cases, save a water blank and follow the Administrator's directions on analysis. Perform the acetone rinses as follows: Carefully remove the probe nozzle and clean the inside surface by rinsing with acetone from a wash bottle and brushing with a Nylon bristle brush. Brush until the acetone rinse shows no visible particles, after which make a final rinse of the inside surface with acetone. Brush and rinse the inside parts of the Swagelok fitting with acetone in a similar way until no visible particles remain. Rinse the probe liner with acetone by tilting and rotating the probe while squirting acetone into its upper end so that all inside surfaces will be wetted with acetone. Let the acetone drain from the lower

end into the sample container. A funnel (glass or polyethylene) may be used to aid on transferring liquid washes to the container. Follow the acetone rinse with a probe brush. Hold the probe in an inclined position, squirt acetone into the upper end as the probe brush is being pushed with a twisting action through the probe; hold a sample container underneath the lower end of the probe, and catch any acetone and particulate matter which is brushed from the probe. Run the brush through the probe three times or more until no visible particulate matter is carried out with the acetone or until none remains in the probe liner on visual inspection. With stainless steel or other metal probes, run the brush through in the above prescribed manner at least six times since metal probes have small crevices in which particulate matter can be entrapped. Rinse the brush with acetone, and quantitatively collect these washings in the sample container. After the brushing, make a final acetone rinse of the probe as described above. It is recommended that two people clean the probe to minimize sample losses. Between sampling runs, keep brushes clean and protected from contaminations. After ensuring that all joints have been wiped clean of silicone grease, clean the inside of the front half of the filter holder by rubbing the surfaces with a Nylon bristle brush and rinsing with acetone. Rinse each surface three times or more if needed to remove visible particulate. Make a final rinse of the brush and filter holder. Carefully rinse out the glass cyclone, also (if applicable). After all acetone washings and particulate matter have been collected in the sample container, tighten the lid on the sample container so that acetone will not leak out when it is shipped to the laboratory. Mark the height of the fluid level to determine whether or not leakage occurred during transport. Label the container to clearly identify its contents.

Container No. 3. Note the color of the indicating silica gel to determine if it has been completely spent and make a notation of its condition. Transfer the silica gel from the fourth impinger to its original container and seal. A funnel may make it easier to pour the silica gel without spilling. A rubber policeman may be used as an aid in removing the silica gel from the impinger. It is not necessary to remove the small amount of dust particles that may adhere to the impinger wall and are difficult to remove. Since the gain in weight is to be used for moisture calculations, do not use any water or other liquids to transfer the silica gel. If a balance is available in the field, follow the procedure for container No. 3 in Section 4.3. Impinger Water. Treat the impingers as follows; Make a notation of any color or film in the liquid catch. Measure the liquid which is in the first three impingers to within ± 1 ml by using a graduated cylinder or by weighing it to within ± 0.5 g by using a balance (if one is available). Record the volume or weight of liquid present. This information is required to calculate the moisture content of the effluent gas. Discard the liquid after measuring and recording the volume or weight, unless analysis of the impinger catch is required (see Note, Section 2.1.7). If a different type of condenser is used, measure the amount of moisture condensed either volumetrically or gravimetrically. Whenever possible, containers should be shipped in such a way that they remain upright at all times.

Inside of nozzle, probe, and glassware (before the filter) rinsed and brushed in triplicate (minimum)?

Is filter holder disassembled on site or transported to lab intact? (circle)

Some test companies will perform the entire clean-up on site. Others may perform part of the clean-up on site, and transfer the filter holder assembly, with the filter, to the lab for disassembly in a "clean" area.

For measurement of condensibles - Liquid in impingers shipped to lab? (May not be applicable)

Regulation: SIP Sources require 1hr particulate test runs and a minimum sample of 30 dscf. NSPS regulations may require different sample rates, times, and temperatures. Investigate prior to test.

Process Data: Absolutely imperative for the facility to record the pertinent data during the test so that the measured emissions can be correlated to a production rate and compared to the permit limit. The test will be unacceptable without production data.

Method 1: If stack is between 4" - 12" then Method 1a must be employed. If duct is <4" then alternative methods must be used (contact SSCU with any test questions)

Stack Diameter? _____ Measured on site?

Port distance from upstream disturbance (A) _____ Upstream Diameters (A) _____

Port distance from downstream disturbance (B) _____ Downstream Diameters(B) _____
 # of Sampling Points? _____ (Draw a line vertically from the "Distance A" axis down to the step chart, and from the "Distance B" axis up to the step chart. The maximum # of points marked on the chart yields the minimum # of points to be sampled.)

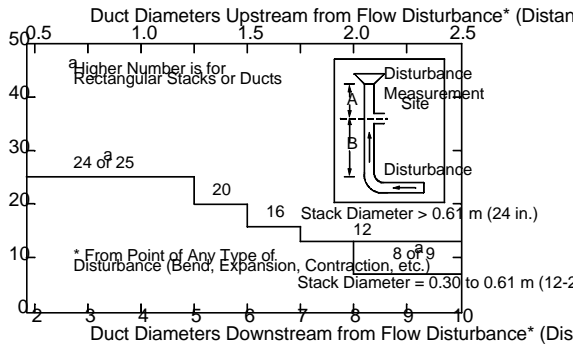

Figure 1-1. Minimum number of traverse points for particulate traverses.

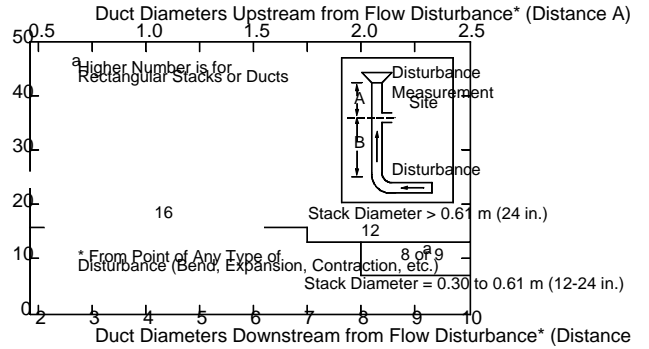

Figure 1-2. Minimum number of traverse points for velocity (nonparticulate) traverses.

Points correctly marked on the pitot tube? _____ Port length accounted for in calculations? _____

Remarks: _____

Barometric Pressure: Barometric pressure must be adjusted minus 0.1" per 100ft elevation increase or vice versa for elevation decrease. (Elevation at which barometric pressure is measured to the elevation at the test platform.)

Orsat, Analyzer or Fyrites: The measurement of O₂ & CO₂ is usually performed with an Orsat. However, it is acceptable to use an analyzer if it has been calibrated per Method 3a. Fyrites are acceptable for CO₂ measurement. An O₂ fyrite can be grudgingly accepted when the results are used to calculate molecular weight only. In no case shall an O₂ fyrite be accepted if the emission standard is in terms of lb/mmBtu or corrected to a percentage of oxygen.

Orsat Triplicate: For each test run there must be three individual analysis of the O₂ & CO₂ concentrations in the flue gas. The analysis must be repeated until the following analysis criteria is met:

CO₂ - any three analyses differ by

- a) <0.3% when CO₂ > 4.0%
- b) <0.2% when CO₂ < 4.0%

O₂ - any three analysis differ by

- a) <0.3% when O₂ > 15.0%
- b) <0.2% when O₂ < 15.0%

Calculate F_o:

$$\frac{(LW - \%)}{\%C} C$$

Coal:	Anthracite and lignite	1.016 - 1.130	Gas:	Natural	1.600 - 1.836
	Bituminous	1.083 - 1.230		Propane	1.434 - 1.586
Oil:	Distillate	1.260 - 1.413		Butane	1.405 - 1.553
	Residual	1.210 - 1.370	Wood:		1.000 - 1.120

Exit Temperature: The temperature of the dry gas leaving the impingers/condenser must be below 68F. When the ambient temperature is above 68F it may take approximately 5 minutes for the thermal effects of the ice bath to cool the exit thermometer below 68F.

Leak Check: If the results of the leak check indicate a leak (>0.02cfm), record the leakage rate. Suggest repeating the run, but it is the discretion of the test team and facility to accept the leak. However, the sample volume will be adversely adjusted due to the leakage rate.

Isokinetics: If the test team indicates that the isokinetic rate of a run is over 110% or under 90%, the run should be voided and repeated.

Particulate Sample Clean-up: If any particulate sample is lost during clean-up, the run should be voided and repeated.

Remarks: _____

This page was intentionally left blank.